

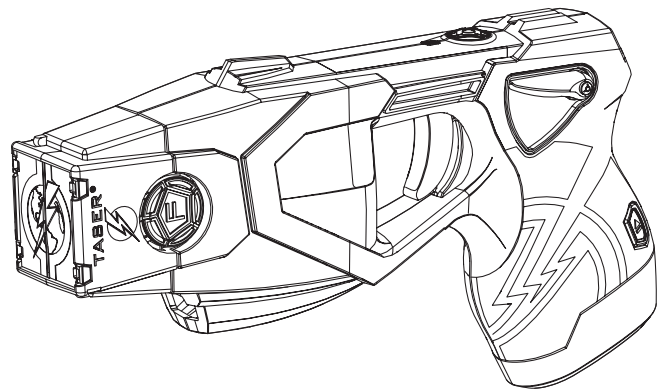

# TASER<sup>®</sup> X26P<sup>™</sup> CEW

## User Manual



Models 11000, 11001, 11002, 11003



### **IMPORTANT SAFETY INSTRUCTIONS.**

Read all warnings and instructions. Save these instructions.

The most up-to-date warnings and instructions are available at [www.TASER.com](http://www.TASER.com).

MMU0042 Rev: B

# Contents

## **4 Chapter 1: Warnings**

- 4 Important Safety and Health Information
- 4 Use of Force Policy
- 5 Firmware Update

## **6 Chapter 2: General Information**

- 6 What is the TASER X26P CEW?
- 6 Neuro Muscular Incapacitation (NMI)
- 7 Basic X26P CEW Electrical Theory

## **8 Chapter 3: Features**

- 8 X26P CEW Features
- 8 Safety Switch
- 9 LASER
- 9 Mechanical Sights
- 9 Tactical Accessory Power Interface
- 9 Performance Power Magazine (PPM) Battery Pack
- 10 Changing the Battery Pack
- 11 Tactical Performance Power Magazine (TPPM) Battery Pack
- 11 eXtended Performance Power Magazine (XPPM) Battery Pack
- 11 Automatic Shut-Down Performance Power Magazine (APPM) Battery Pack
- 12 eXtended Automatic Shut-Down Performance Power Magazine (XAPPM) Battery Pack
- 12 Advanced Central Information Display (CID)
- 12 System Status Icons
- 13 Battery Level Icons
- 14 Spark Duration
- 14 Sample CID Displays
- 15 LED Flashlight
- 15 Selector Switch (LASER and LED Flashlights)
- 16 Trigger Switch
- 17 Ergonomic Grip Design





## **18 Chapter 4: Cartridges & CEW Operation**

- 18 Removing the Shipping Cover from the Cartridge
- 18 15, 21, LS, and XP25™ TASER Cartridges
- 19 AFID
- 19 Load the TASER Cartridge

|    |   |
|----|---|
| 20 | Loading   |
| 20 | Unloading                                       |
| 20 | Aiming and Probe Placement                      |
| 21 | "Silence Is Golden"                             |
| 21 | Potential Causes of Reduced or No Effectiveness |
| 21 | Electrodes                                      |
| 22 | Drive-Stun Backup                               |
| 23 | Recommended Drive-Stun Areas for Maximum Effect |
| 24 | <b>Chapter 5: Maintenance/Troubleshooting</b>   |
| 24 | Function Test                                   |
| 24 | Function Test Instructions                      |
| 25 | What to Do Following CEW Use                    |
| 25 | Considerations for Handling Used Probes         |
| 25 | Effects On Animals                              |
| 26 | Police/Military K-9 Caution                     |
| 26 | Uploading Firmware Revisions                    |
| 26 | Dataport Download Kit                           |
| 26 | USB Connection Status                           |
| 26 | EVIDENCE Sync Offline Software                  |
| 27 | Trilogy Log                                     |
| 27 | Event Log                                       |
| 28 | Pulse Log                                       |
| 28 | Engineering Log                                 |
| 28 | Time Synchronization                            |
| 28 | X26P CEW Maintenance and Care                   |
| 29 | Dropped or Wet X26P CEW                         |
| 30 | TASER Online Troubleshooting Guide              |
| 30 | Product Returns                                 |
| 31 | <b>Chapter 6: Optional Accessories</b>          |
| 31 | EVIDENCE.com                                    |
| 31 | EVIDENCE Sync Offline Software                  |
| 31 | TASER CAM HD Recorder                           |
| 32 | Holsters  |
| 33 | <b>Chapter 7: Additional Items</b>              |
| 33 | Additional Information                          |
| 33 | TASER Training Academy                          |
| 34 | Medical Research                                |

## Important Safety and Health Information

Read, understand and follow the most current product warnings, safety instructions, and training materials. All product warnings are not included in this Manual. A Product Warnings document is included with this conducted electrical weapon (CEW) and the most current warnings are posted on our website at [www.TASER.com](http://www.TASER.com). The most current training materials are available by contacting TASER’s Training Department. Do not attempt to use this CEW until you have completed training with a TASER International, Inc. (TASER) Certified Instructor.

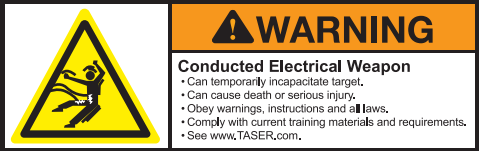
|  <b>WARNING</b> |  |
|--|--|
|                 | <p><b>Complete Training First</b><br/>                     Significant differences exist between each of the TASER CEW models. Do not use or attempt to use any CEW model unless you have been trained and certified by a Certified TASER Instructor on that particular model.</p>   |
|                | <p><b>Read and Obey</b><br/>                     Read, study, understand, and follow all instructions, warnings, information, training bulletins and TASER training materials before using the TASER X26P™ CEW. Failure to comply with the product instructions, warnings, information, training bulletins, and TASER training materials could increase the risk of or result in death or serious injury to the user, force recipient, and others.</p> |
|               | <p><b>Obey Applicable Laws</b><br/>                     Use the CEW only in accordance with applicable federal, state, and local laws and other regulations or legal requirements. Your agency’s guidance must also be followed. Any CEW use must be legally justifiable.</p>  |
|              |  |

TASER® CEWs are designed in probe-deployment mode to temporarily incapacitate a person from a safer distance while reducing the likelihood of serious injuries or death. When used as directed, TASER CEWs have been found to be safer and more effective than other traditional use-of-force tools and techniques. However, it is important to remember that the use of force and physical incapacitation, by their very nature, involve risk that someone will get hurt or may even die from factors that include, but are not limited to: physical resistance, exertion, individual susceptibilities, and/or unforeseen circumstances. Any use of force or physical exertion involves risks that a person may get hurt or die.

## Use of Force Policy

Each agency is responsible for creating its own use-of-force policy and determining how TASER CEWs fit its their use-of-force matrix based on legal and community standards. Make sure your agency has a use-of-force policy

that addresses TASER CEW use and that this policy is clearly addressed during end-user training.

## Firmware Update

Before using your X26P CEW, confirm with your armorer or other qualified person that the X26P firmware has been updated.

## What Is the TASER X26P CEW?

The X26P CEW is a software upgradable weapon manufactured by TASER International, Inc.

The X26P CEW uses a replaceable cartridge containing compressed nitrogen to deploy two small probes that are attached to the X26P CEW cartridge by insulated conductive wires. The cartridges are available with various wire lengths from 15' to 25' (4.6 m to 7.6 m). Sale of cartridges with wire length longer than 15' is limited to law enforcement and military only.

The X26P CEW's Trilogy™ log can be uploaded securely to EVIDENCE.com. The X26P CEW has an internal memory that stores the operating software and a deployment record. See the **Trilogy Log** section in this manual for more details. Those who do not have an EVIDENCE.com account can use the Offline EVIDENCE Sync software to download a simplified log to a local computer.

The X26P CEW has an estimated useful life of 5 years.

## Neuro Muscular Incapacitation (NMI)

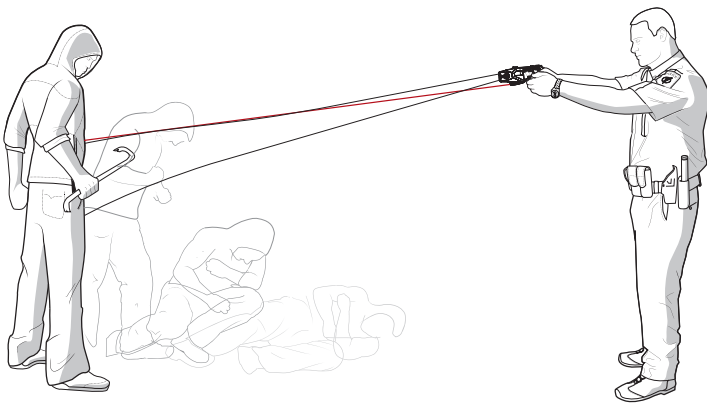

TASER technology is designed to use electrical impulses similar to those in your body's nervous system to cause stimulation of the sensory and motor nerves. Neuro Muscular Incapacitation (NMI) occurs when a CEW is able to cause involuntary stimulation of both the sensory nerves and the motor nerves. It is not dependent on pain and can be effective on subjects with a high level of pain tolerance.

Previous generations of stun guns primarily affected the sensory nerves only, resulting in pain compliance. A subject with a very high tolerance to pain (e.g., a drug abuser, person in serious psychological distress, or a trained, focused fighter) may not be affected by the pain or might be able to fight through the pain of a traditional stun gun.

## Basic X26P CEW Electrical Theory

- Electricity must be able to flow between the probes to deliver an electrical charge and will generally follow the path of least resistance between the probes.
- The greater the spread between the probes on the target, generally the greater the effectiveness.
- Electricity will generally not pass to others in contact with the subject unless contact is made directly between or on the probes, or the wires are touched.
- Electricity can arc through most clothing, and even some bullet-resistant materials.
- Exposure to water will not cause electrocution or increase the power to the subject (the electrical charge is fixed inside the TASER CEW, and will not increase significantly even with environmental changes).
- The Current Metering technology is designed to deliver optimal charge.
- Medical studies have found that modern pacemakers and implanted cardiac defibrillators withstand external electrical defibrillators many orders of magnitude stronger than the TASER CEW conducted energy pulses.

## X26P CEW Features

Get to know the X26P CEW:

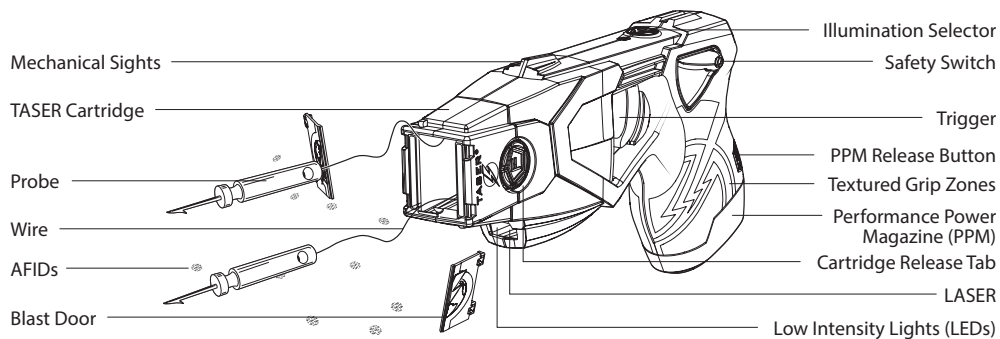

NOTE: The serial number is located inside the cartridge bay.

**Ensure the CEW is unloaded, the safety is in the down (SAFE) position, and your fingers are away from the trigger before reading the serial number.**

## Safety Switch

Ambidextrous safety can be operated from either side of the CEW.

- Safety switch down (SAFE).
- Safety switch up (ARMED) and ready to deploy.
- Do not block the safety on one side of the X26P CEW while attempting to move it on the other side. This can break the safety and disable the CEW.
- With default settings, if the X26P CEW's safety switch is left in the up (ARMED) position for more than 20 minutes, the system goes into low power mode to reduce the amount of power consumed, and the CEW will not fire. Although the CEW will not fire, power is still consumed and will eventually drain the battery if the safety switch remains in the 'ARMED' position. To re-arm the CEW, shift the safety to the down (SAFE) position, and then shift it back to the up (ARMED) position.



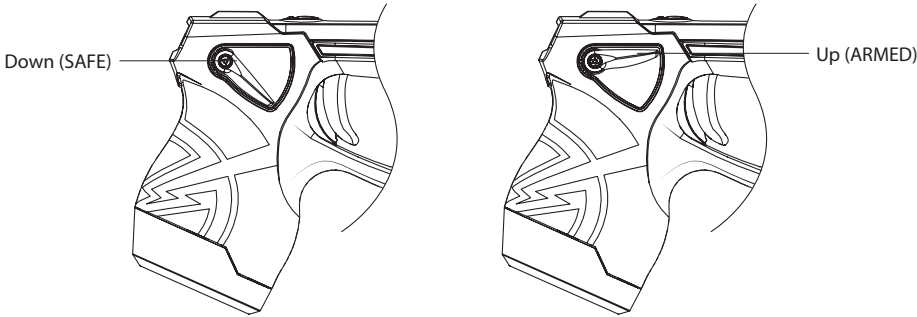

## LASER

The LASER installed in the X26P CEW is oriented with the mechanical sights. At 15 feet (4.6 m), the aiming point is aligned to the approximate trajectory of a cartridge's top probe.

## Mechanical Sights

The mechanical sights on the X26P CEW are molded to provide manual aiming of the CEW. The mechanical sights are set to coincide with a top probe's trajectory at a 15' (4.6 m) distance.

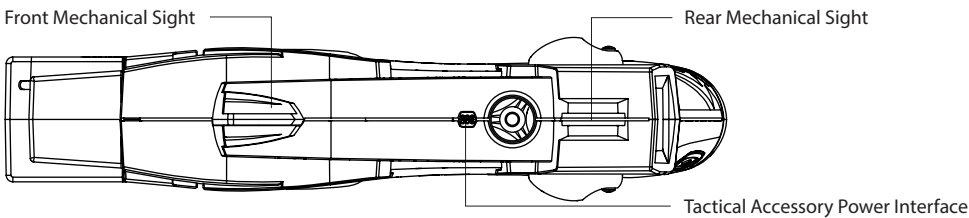

## Tactical Accessory Power Interface

This is a power plug for future X26P accessories.

## Performance Power Magazine (PPM) Battery Pack

The Performance Power Magazine is a lithium energy cell power supply system for the X26P CEW.

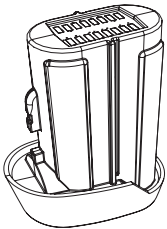

NOTE: X26P battery packs will not work with the X3<sup>®</sup> or X26<sup>™</sup> CEWs, and battery packs designed for the X3 or X26 CEWs will not work with the X26P CEW. Battery packs designed for the X2<sup>™</sup> CEW will work in the X26P CEW.

Do not store the PPM anywhere that the gold contacts on the top of the PPM may touch metal objects. If you

cause an electrical short between these contacts, the short will drain the battery and may cause the pack itself to become dangerously hot.

The PPM battery has enough power for approximately 500 five-second discharges depending on temperature, environment, use of the flashlight, and other factors. The PPM battery will deplete faster in colder weather than warm weather. Likewise, the battery will deplete faster with the flashlight active.

For more information on installing the PPM, see the *Changing the PPM Battery Pack* section in this manual.

NOTE: Other battery pack options are available for the X26P CEW. See the *Tactical Performance Power Magazine (TPPM) Battery Pack*, *Automatic Shut-Down Performance Power Magazine (APPM) Battery Pack*, and *eXtended Performance Power Magazine (XPPM) Battery Pack* sections in this manual.

## Changing the Battery Pack

To change the battery pack:

- 1 Point the CEW in a safe direction.
- 2 Ensure the safety switch is in the down (SAFE) position.
- 3 Safely remove the TASER cartridge (do not place any body parts in front of the cartridge). See the *Unloading* section in this manual for more information.
- 4 To unload the battery pack, depress the battery pack release button and remove the battery pack from the handle of the CEW.

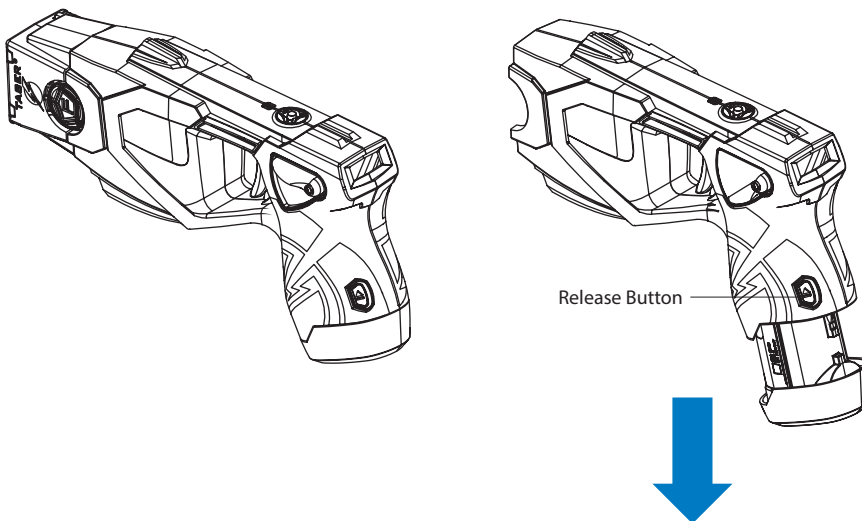

- 5 Inspect the battery contacts. Ensure that they appear in working order and are free from dirt or other residue that may interrupt the battery connection to the CEW.
- 6 Install the new battery pack and ensure that it is fully inserted in the X26P CEW. Apply sufficient force to ensure the battery pack is fully seated. When the battery pack seats properly, the release button should pop out from the recessed portion with an audible click.

## Tactical Performance Power Magazine (TPPM) Battery Pack

The optional TPPM has an extension to provide a larger grip on the CEW. The TPPM does not hold an extra cartridge.

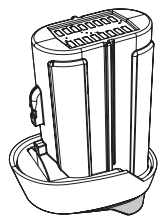

## eXtended Performance Power Magazine (XPPM) Battery Pack

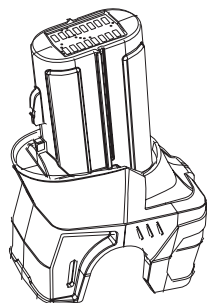

To install a TASER standard cartridge in an XPPM:

- 1 Ensure the cartridge cover is removed. See the *Removing the Shipping Cover from the Cartridge* section in this manual for more information.
- 2 Keeping your hand away from the blast doors, depress the tabs on the sides of the cartridge.
- 3 Insert the cartridge in the XPPM so the blast doors face forward, toward the front of the CEW.

To remove the cartridge, keeping your hand away from the blast doors, depress the tabs again and pull the cartridge out of the XPPM.

## Automatic Shut-Down Performance Power Magazine (APPM) Battery Pack

The optional APPM is a modified battery pack that shuts down the output of the X26P CEW after 5 seconds and also contains a built-in speaker that alerts you to the impending shut down.

**Under stressful situations, audio exclusion might prevent you from hearing the alert from the APPM.**

The APPM provides an audible beeping alert for the last 2 seconds of a trigger-initiated cycle before automatically shutting down the cycle. After 5 seconds' deployment duration, the energy burst will stop even if your finger is still pulling the trigger switch. To reenergize the deployed cartridge, first ensure that your finger is off the trigger switch, and then press the trigger again.

Your CEW will recognize the APPM as a unique type of battery pack. If you remove the APPM and replace it with a different type of battery pack, the X26P CEW will return to its normal configuration. That is, there will no longer be an audio alert, and the energy cycle will continue after 5 seconds if your finger is still holding down

the trigger switch. Always confirm that the CEW performs as expected before returning it to duty after changing any battery pack.

Remove the cartridge before testing the CEW function. See the *Unloading* section in this manual for more information.

## eXtended Automatic Shut-Down Performance Power Magazine (XAPPM) Battery Pack

The XAPPM holds an extra TASER standard cartridge like the XPPM and features an automatic output shut down after 5 seconds like the APPM.

## Advanced Central Information Display (CID)

The CID is a monochrome organic light emitting display on the back of the X26P CEW. When the safety switch is shifted into the up (ARMED) position, the CID will display the battery status.

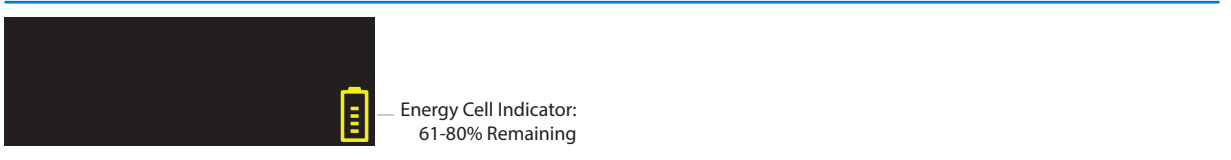

## System Status Icons

The system status icons are designed to inform you of the system status of the X26P CEW. It is the user's responsibility to conduct proper maintenance, and ensure that the CEW is working properly before any use. Failure to heed the system status icons could cause serious injury or death.



**Major Fault indication.** A yellow triangle indicates that the logging or date and time functions are not working properly. The CEW will still produce an electrical output (e.g., the CEW should still arc and deploy cartridges), but the accountability functions are compromised.

Shift the safety switch to the down (SAFE) position and then to the up (ARMED) position; the fault may clear. If the fault does not clear, it may still be possible to use the CEW for a short time.

Whether the fault clears or not, it will be recorded in the Engineering log. If the fault does not clear, and the CEW is still under warranty, send the CEW to TASER for repair.

---



**Critical Fault indication.** A yellow stop sign in the upper-right side of the CID indicates a system failure.

Critical faults are rare. Shift the safety switch to the down (SAFE) position and then to the up (ARMED) position; the fault may clear.

If the fault does not clear, do NOT attempt to use the CEW. The CEW may need to be repaired or replaced. See the *Product Returns* section in this manual for instructions.



**Invalid Battery Pack.** If you see a blinking exclamation point and battery icon, this indicates that the CEW did not recognize the battery correctly. Remove the battery pack and reinsert it. If the error is still present, try another battery pack. If the icon still displays, the CEW should be sent in for service if it is still under warranty.



An APPM or XAPPM battery pack is installed in the CEW.



A TASER® CAM™ HD recorder is installed in the CEW.



A TASER CAM™ HD recorder with the automatic shut-down feature is installed in the CEW. This recorder offers an audio warning and shut-down feature like that of an APPM battery pack.



The USB connection status icon displays when the USB connection is good.

## Battery Level Icons

When the safety switch is in the up (ARMED) position, the CID will display the percentage of battery power remaining. Remaining capacity will display in 19 percent increments.

When the battery level drops to 20 percent, TASER recommends that the battery pack be replaced.



Battery  
81–100%



Battery  
61–80%



Battery  
41–60%



Battery  
21–40%



When the battery capacity is at 1–20 percent, the CID will flash the warning **LO BATT** on the CID when the safety switch is cycled to the up (ARMED) position.



Battery  
01–20%  
Blinking

If the battery capacity is at 1–20 percent, and the CEW is being discharged, this icon displays in the lower-right portion the CID.



When the TASER CAM HD battery is depleted, the CID will flash the warning **RECHARGE BATTERY** on the CID when the safety switch is cycled to the up (ARMED) position.



Battery  
Depleted

When the PPM, TPM, APPM, XPPM, or XAPPM battery pack is depleted, the CID will flash the warning **CHANGE BATTERY** on the CID when the safety switch is cycled to the up (ARMED) position.

## Spark Duration

The CID displays a count indicating how many seconds the deployment cycle lasts. The CEW will count up from the number 1 up to 99. At 99 seconds, the count will restart at 1.



## Sample CID Displays

The CID below shows the X26P CEW with a TASER CAM HD recorder installed and a battery capacity of 61–80 percent.



The CID below shows a CEW that has been discharging for 4 seconds, with a battery pack that is at 41–60 percent capacity.



The CID below shows a CEW with an APPM battery pack installed that has a battery capacity of 61–80 percent.



The CID below shows a CEW with a battery pack error.



The CID below shows a CEW that is 4 seconds into an energy burst, has a battery pack that is 81–100 percent charged, and a major fault with the CEW.



## LED Flashlight

The X26P CEW has a high intensity white LED to aid the user in dark environments.



## Selector Switch (LASER and LED Flashlights)

You can select four modes of illumination when using the X26P CEW. To change the illumination setting:

- 1 Point the CEW in a safe direction.
- 2 Ensure the safety switch is in the down (SAFE) position.
- 3 Keeping your hand away from the blast doors, depress the tabs on the sides of the cartridge and remove.
- 4 Press and hold the selector switch for approximately 1 second until the CID display illuminates.

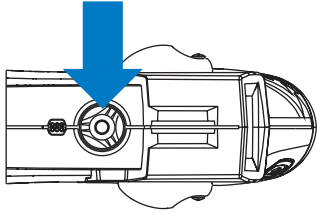

NOTE: Using pens or paper clips to press the selector switch may damage it. Only use your finger to press the selector switch.

- 5 Press and release the selector switch to toggle through the four available settings until the setting you desire is designated on the CID. Stop when the setting you desire is displayed.



**OO:** Neither the LASER nor the Flashlight will illuminate.

**LO:** Only LASER will illuminate

**OF:** Only Flashlight will illuminate

**LF:** LASER and Flashlight both illuminate

The selected mode displays for 5 seconds, and will be the default mode the next time the safety switch is moved to the up (ARMED) position.

The selector switch may also be used to activate the Stealth Mode, which will shut off the LASER and flashlight, and dim the CID display. To do this, press the selector switch when the safety is in the up (ARMED) position. To take the CEW out of Stealth Mode, press the selector switch again or shift the safety to the down (SAFE) position. You will have to reactivate the Stealth mode each time you place the safety in the up (ARMED) position.

## Trigger Switch

Unlike a firearm trigger, the X26P CEW trigger is a momentary electrical switch. The switch is operational only when the safety switch is in the up (ARMED) position. Pulling and releasing the trigger switch will result in an approximately 5-second discharge cycle unless the safety switch is shifted to the down (SAFE) position to discontinue the 5-second cycle. Pulling and holding the trigger switch for more than 5 seconds will result in a continuous discharge until the trigger switch is released, or the battery is depleted—whichever comes first.

An X26P CEW equipped with the APPM battery pack is limited to 5-second discharges and emits an audio alert 2 seconds before the end of the cycle. See the *Automatic Shut-Down Performance Power Magazine (APPM) Battery Pack* section in this manual for more information.

**In the event of an accidental discharge, immediately move the safety switch to the down (SAFE) position to stop the discharge cycle.**



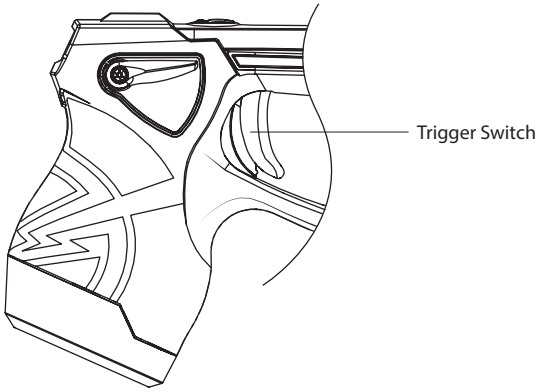

## Ergonomic Grip Design

The handle of the X26P CEW is optimized for comfort with specific features for safe and effective use for people of most sizes.

## Removing the Shipping Cover from the Cartridge



Cartridges are sold separately from the CEW. Cartridges are shipped with a shipping cover in place. Carefully remove these covers before attempting to load a cartridge into the X26P CEW. Be careful to not allow any body part to be in front of the cartridge. Static electricity can discharge a cartridge, and injuries have occurred. A cartridge cannot be loaded into the CEW with the cover in place. Once the cartridge cover is removed, it can be disposed of.

- 1 Before removing the covers, make sure the front of the cartridge does not point at any body part or at anyone.
- 2 Carefully place the cartridge with cover face down (blast door down) onto a stable/solid surface, i.e., a table.
- 3 Place your index and middle fingers onto the sides of the cartridge where the wedges/electrodes are located and place your thumbs onto the locking portions of the cover.
- 4 Push in with your fingers and pull outward with your thumbs and the cartridge will pop upward, releasing it from the cover.

NOTE: The cartridge may pop upward quickly when the pressure is released from the locking portions of the cover.

## 15, 21, LS, and XP25™ TASER Cartridges

**Never attempt to open or modify a TASER cartridge. Tampering with a live TASER cartridge could cause it to fire or malfunction (which may result in serious injury).**

**Handle all TASER cartridges with care. Probes may deploy unexpectedly if exposed to physical shock, or static electricity.**

TASER cartridges should be kept away from conditions known to create an electrostatic discharge, such as rubbing cloth (e.g., jacket liner or uniform pants) across a cartridge in an environment known to create static shocks.

Cartridge blast doors can be knocked off the front of a cartridge. Because those cartridges cannot be relied upon to consistently discharge, TASER recommends removing those cartridges from service. Attempting to deploy

a cartridge with no blast doors could result in a charge being created and held in the wires. Any conductive material that comes into contact with the front of the cartridge, even after the cycle has ended, could draw the charge to the ignition pin and deploy the probes.

TASER offers a Blast Door Repair Kit that can be used to replace blast doors that come off. Cartridges with replaced blast doors should only be used for training and should not be deployed to the field. Go to [www.TASER.com](http://www.TASER.com) for more information on the Blast Door Repair Kit.

## AFID

Every time a TASER cartridge is deployed, approximately 20–30 small confetti-like Anti-Felon Identification (AFID) tags are ejected. Cartridges can be assigned to individual users, as each is serialized. Each AFID tag is printed with the corresponding serial number of the cartridge deployed, allowing determination of which user deployed the particular cartridge.

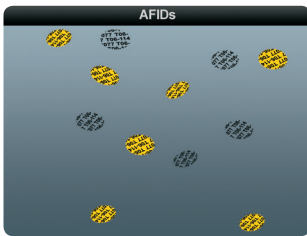

## Load the TASER Cartridge

**Never place your hands or fingers in front of the cartridge. This is especially important when loading and unloading the cartridge. Serious injury could result. When loading and unloading always hold the cartridge on the sides or top.**

TASER cartridges are shipped with a shipping cover in place. Remove these covers before attempting to load a cartridge into an X26P CEW. See the *Removing the Shipping Cover from the Cartridge* section in this manual for more information.

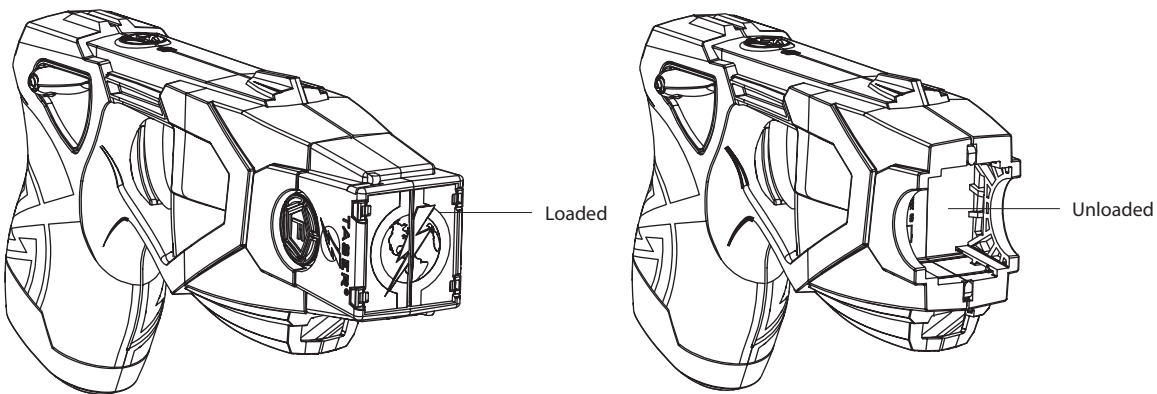

## Load the TASER Cartridge

### Loading

- 1 Point the CEW in a safe direction.
- 2 Ensure that the safety switch is in the down (SAFE) position.
- 3 Make sure the protective shipping cover is removed from the TASER cartridge.
- 4 Keeping your hand away from the blast doors, place the cartridge (with the cartridge cover removed) into the front of the CEW until an audible click is heard.
- 5 Verify that the cartridge is secure by pulling on the sides of the cartridge.

## Load the TASER Cartridge

### Unloading

- 1 Point the CEW in a safe direction.
- 2 Ensure that the safety switch is in the down (SAFE) position.
- 3 Keeping your hand away from the blast doors, depress the tabs on the sides of the cartridge and remove.

The 15-, 21-, and 25-foot (4.6-, 6.4-, and 7.6-meter, respectively) TASER cartridges are specifically designed so there is no “up” or “down” position – enabling you to quickly reload one in a stressful situation without worrying about putting it in upside down.

## Aiming and Probe Placement

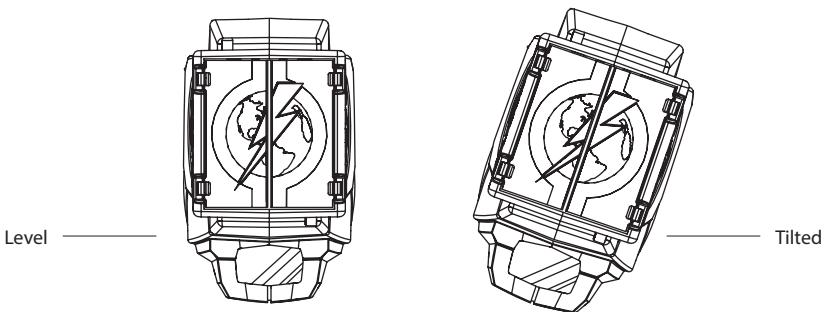

For most deployments, hold the CEW level. Do not tilt the CEW unless it is necessary to do so to align the CEW with the target.

All TASER CEW deployments should be in accordance with current TASER training and warnings, and department training, policies, and procedures.

Normally, aim the LASER at the preferred target areas of the body, which are the lower center-mass (below the chest) and legs when the subject is facing you, or the subject’s back if the subject is turned away from you.

**When possible, avoid intentionally targeting the CEW on sensitive areas of the body such as the head, throat, chest/breast, or known pre-existing injury areas without legal justification.**

The top probe impacts the target near the LASER beam; however, the probe impact distance from the LASER will vary depending on the distance between the CEW and the target, type of cartridge, etc. At 15' (4.6 m), the

LASER's position corresponds to the trajectory of a 25' (7.6 m) cartridge's top probe at the same range.

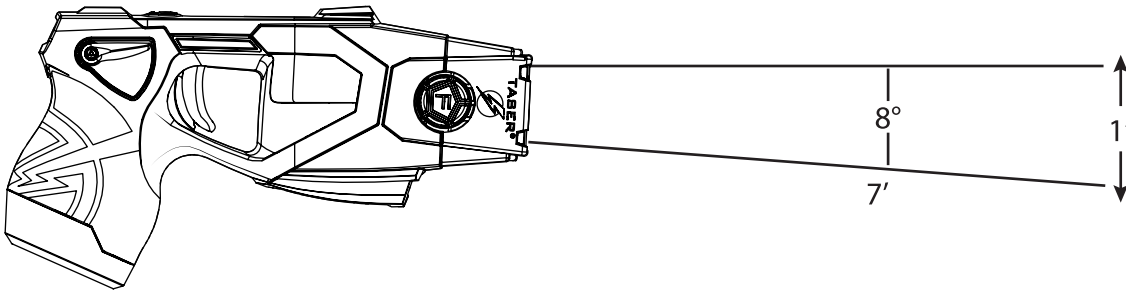

The bottom probe impacts at an 8-degree angle from the top probe. This results in a spread of approximately 1' (0.3 m) for every 7' (2.1 m) of distance from the CEW. Greater probe spread increases effectiveness.

## “Silence Is Golden”

The TASER CEW's electrical current is relatively quiet when both probes make direct contact with a human or an animal. In contrast, some practice conductive targets are loud because the energy is arcing in the air.

If electrical current is loud during field deployment and the subject is not reacting as expected, the electrical circuit may not be completed or the current may be shorting out and may not be effective. Deploy a second cartridge or consider other options in accordance with your agency's policies.

## Potential Causes of Reduced or No Effectiveness

- **Loose or Thick Clothing.** If the probes lodge in clothing and are too far away from the subject, CEW effectiveness is reduced and can be eliminated.
- **Miss or Single Probe Hit.** The current must pass between the probes. If one probe misses, a second cartridge should be deployed if practical and legally justifiable. Also, using the X26P CEW in the drive-stun mode as described below may complete the circuit between the single probe and the CEW electrode.
- **Low Nerve or Muscle Mass.** If the probes impact in an area where there is very little muscle mass (e.g., the side of the rib cage), the effectiveness can be significantly diminished.
- **Limited Probe Spread.** Probe spreads of less than 4 inches (10 cm) (including drive-stun) may result in little or no effect and become primarily a pain compliance option.
- **Wires Break.** If a wire breaks (e.g., during a struggle), the current will not flow to the probes and an additional deployment may be required. Drive-stun may still be available.

**Do not become over-dependent on the TASER CEW. No force option, including CEWs, is 100% effective in every situation. Do not deploy the CEW without following your department policies and procedures.**

## Electrodes

The front of the X26P CEW has two metal electrodes. These electrodes direct the charge to the electrodes on the cartridge to initiate deployment of the probes. In addition, the electrodes provide the ability to use the X26P CEW in a “drive-stun” mode as a traditional stun-gun type CEW.

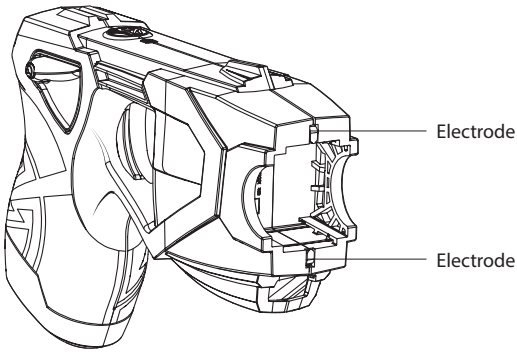

## Drive-Stun Backup

Drive-stun capability is available with or without a TASER cartridge installed. To apply a drive-stun, place the safety in the up (ARMED) position and pull the trigger. The drive-stun mode is not designed to cause incapacitation and generally becomes primarily a pain compliance option. Probe deployment is usually considered more desirable if incapacitation is the desired objective, even at close range. Some of the advantages of probe deployment include:

- Drive-stun is only effective while the CEW is in contact with the subject or when pushed against the subject's clothing. As soon as the CEW is moved away, the energy being delivered to the subject stops. Deploying the probes allows the user to separate from the subject while maintaining control.
- Due to automatic reflex actions, most subjects will struggle to separate from the CEW. Each time the CEW comes back in contact with the subject, another set of marks may be visible on the subject's skin. Using the probes allows for one point of discharge.
- If the probes are deployed, even at very close range, the user may drive-stun to another portion of the body that is further away from the probes, thereby increasing the possibility of inducing incapacitation.

If the drive-stun is not effective, evaluate the location of the drive-stun, consider an additional cycle to a different pressure point, or consider alternative force options in accordance with your agency's policies. When using the drive-stun, push (drive) the front of the X26P CEW firmly against the body of the subject. Simply "touching" the X26P CEW against the subject is not sufficient. The subject is likely to recoil and try to get away from the CEW. It is necessary to aggressively drive the front of the CEW into the subject for maximum effect.

## Recommended Drive-Stun Areas for Maximum Effect

Only use the X26P CEW pursuant to your agency's policies and guidance. Drive the X26P CEW into the following areas for maximum effectiveness:

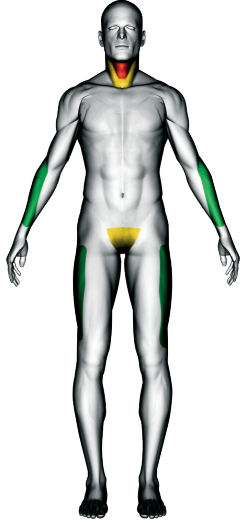

- Carotid (sides of neck) (see warning below).
- Radial (forearm).
- Pelvic triangle (see warning below).
- Outside of thigh.
- Tibialis (calf muscle).

Use care when applying a drive-stun to the neck or groin. These areas are sensitive to mechanical injury (such as crushing to the trachea or testicles if applied forcefully). However, these areas have proven highly effective targets. These areas should only be targeted when users are defending themselves from violent attacks. Refer to your department's policy regarding drive-stuns in these and other sensitive areas.

## Function Test

TASER recommends conducting a function test every 24 hours or prior to the start of your shift for your individually issued X26P CEW. The function test is done to verify that the CEW's core electronics are working properly.

There is no need to use an extended duration. As long as you see a visible spark between the electrodes (2 to 3 seconds), the X26P CEW is functional.

## Function Test Instructions

- 1 Point the CEW in a safe direction.
- 2 Shift the safety switch to the down (SAFE) position.
- 3 Remove the TASER cartridge. A function test should never be conducted with a TASER cartridge in the CEW.
- 4 Ensure that your fingers and no other part of your body are in front of the X26P CEW.
- 5 Shift the safety switch to the up (ARMED) position.
- 6 Pull the trigger and visually confirm sparking across the electrodes.

**View the arc from the top or side of the CEW. Do not point the CEW at your face or have it near your face.**

- 7 Look at the CID display and verify the following:
  - No fault icons display on the CID.
  - The battery icon displays a 20 percent or greater capacity.

If any of the above verifications fail, return the unit to your agency's CEW technician for service.

- 8 Shift the safety switch to the down (SAFE) position.



## What to Do Following CEW Use

### Considerations for Handling Used Probes



#### Biohazard

Each agency will establish its own procedure for probe removal, collection, biohazards, evidence collection and maintenance. Treat probes that have penetrated the body as contaminated needles (biohazard). Remember, however, that the probes may also be valuable evidence.

If the probes must be removed from the subject, follow all department policies and procedures, including for handling biohazards.

Below are suggested methods for probe removal.

- Grab the probe firmly and quickly pull it straight out. Do not twist the probe as the barbed tip may cause additional injury.
- If the probes are not going to be collected and maintained for evidence, carefully place used probes sharp-tip first into a sharps container, secure in place, and place in a secure location where no one will accidentally touch the probes.
- Once the subject is restrained, prior to removing the probes, evaluate the need for medical attention as you would with any other use-of-force incident.\*
- Take photos of any injuries, place the photos into evidence.\*
- Collect the expended cartridge, probes, and AFIDs and place them into evidence.\*

\* As directed by department policy. The TASER training materials provide additional information on forensic evidence collection procedures. The probes, wires, AFIDs, and cartridge can yield important forensic evidence if properly collected, maintained, and analyzed. Ensure that the CEW is downloaded and the downloaded logs are collected per your agency's policy.

## Effects on Animals

The M26 and X26 CEWs can be an effective option for dealing with aggressive animals and have generally been successful in most deployments. The X26P CEW uses similar technology, but does not yet have the same service record as the previous models.

NOTE: If a probe deployment completed circuit is initiated and maintained, the aggressive animals are usually incapacitated/stunned momentarily in M26 and X26 deployments, but recover quickly. The vast majority of the animals quickly left the scene and broke the wires.

If deployed on a domestic animal, consider having animal control available to restrain the animal.

## Police/Military K- 9 Caution

CEW operators and K-9 officers must work closely together to develop policies and procedures for deploying the CEW when a K-9 is present. If a K-9 bites a probe or bites the suspect between the probes, the K-9 could receive a shock. This could have a negative impact on the future duty use of the K-9.

## Uploading Firmware Revisions

The X26P CEW internal firmware provides functionality for all aspects of the CEW. The firmware can be upgraded to the most recent version by using an X26P/X2 CEW Dataport Download Kit (purchased separately) and EVIDENCE Sync software (Online or Offline).

**Do not remove the USB cable or shift the safety switch to the up (ARMED) position during the reprogramming cycle.**

## Dataport Download Kit

Optional download kits are available to permit agencies to access the deployment information in the X26P CEW memory through the EVIDENCE Sync software (Online or Offline).

NOTE: If you have a TASER CAM HD recorder, please see the *TASER CAM HD Operating Manual* and the *EVIDENCE Sync User Manual* for downloading instructions.

The X26P CEW uses a USB adapter (download cable) to connect to any Windows XP or Windows 7 computer. The simplicity of USB makes using the dataport download kit an easy, fast process. The cable connects to the CEW through the battery compartment.

## USB Connection Status

The USB icon will blink at a 1-second rate when the connection is good.



## EVIDENCE Sync Offline Software

If you do not have an EVIDENCE.com account, the EVIDENCE Sync software can be used in the Offline mode to download the simplified Event log to your local computer and print it. The EVIDENCE Sync Offline software will not enable you to download the full Trilogy log.

## Trilogy Log

Upon upload to EVIDENCE.com, the system collects the information into 3 related data logs called the Trilogy logs:

- Event log
- Pulse log
- Engineering log

The data set from the Trilogy log is uploaded securely to EVIDENCE.com, where the information is encrypted, stored securely, and organized into dashboards that allow your agency to easily monitor the usage and system status of your entire arsenal of X26P CEWs.

Upon upload to EVIDENCE.com, the system displays the information from the Event and Pulse logs. Your type of EVIDENCE.com account will determine what data can be viewed from these logs.

## Event Log

The Event log tracks events and may help protect a user from claims of excessive use of force by providing documentation of the time and date for each CEW deployment. The Event log also provides agencies with a powerful management tool to track usage patterns and help prevent misuse. You do not need to download the X26P to EVIDENCE.com services to obtain the Event log – this can be downloaded directly to your PC using the EVIDENCE Sync (Offline) software.

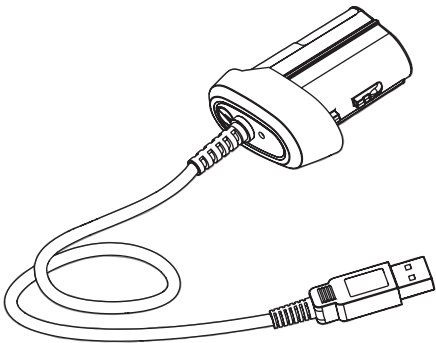

The Event log includes the following information for the most recent (approximately) 16,000 entries:

- Each entry contains the date and time of each event.
- Entries include Armed, Safe, Trigger, USB connection, PowerSave mode, software updates, time synchronizations, language changes, flashlight on/off, etc.
- The duration of each Trigger event.
- The duration of each Safe event (when the safety switch was moved to the down [SAFE] position and how long the CEW was armed).
- The internal temperature is shown for armed session events except for Trigger events.
- Battery percentage is shown for all armed session events (Armed, Trigger, Safe).

When the log fills to approximately 16,000 entries, it will delete the oldest 4,000 records and write new ones. This process will continue in 4,000-record increments.

## Pulse Log

The Pulse log records any pulse activity. The records include how long the CEW was discharged, and the charge of every pulse.

## Engineering Log

The Engineering log monitors the performance of key sub-systems within the X26P CEW. It provides alerts if a subsystem is not performing properly and if maintenance is advisable. Any internal circuitry errors that occur inside the X26P CEW are written to this log. This information is used for diagnostics.

## Time Synchronization

The CEW has a real-time clock powered by the battery pack and an internal battery as well. The CEW should keep accurate time even when the battery pack is removed.

Every time the X26P CEW is connected to EVIDENCE.com services, the system will perform a time synchronization. The conversion to local time, including adjustments to daylight savings time, are all computed by EVIDENCE Sync software. There is no need to program the X26P CEW to local time or to reprogram the CEW to daylight savings time.

NOTE: In EVIDENCE Sync Offline mode, if your computer time is incorrect, the incorrect time will be displayed in your EVIDENCE Sync-generated report.

## X26P CEW Maintenance and Care

Each agency should establish a maintenance and handling program.

**The X26P product is a sensitive piece of electronic equipment, and should be handled with care. Avoid dropping an X26P CEW. Do not use an X26P CEW that has a cracked handle.**

- Check the battery pack regularly. Replace it when the battery percentage reaches 20%.
- Occasionally wipe out the X26P cartridge deployment bay with a dry cloth. Multiple cartridge firings create carbon build-up (particularly after training courses) that should be removed.

**Do not wipe out the X26P cartridge bay immediately after the CEW has been fired as you might receive a latent short electrical shock. Wait at least five minutes after the last discharge of the X26P CEW before wiping out the bay.**

- Secure the X26P CEW in a protective holster when the CEW is not in use.
- Function test the CEW before each shift.
- Update the CEW's firmware when updated firmware is released.
- Download your X26P CEW data to EVIDENCE.com services or your local PC at least once per quarter and always before sending the CEW for repair or warranty work.
- Avoid immersing the X26P CEW in water or exposing the X26P CEW to excessive moisture or water.
- See the troubleshooting guide at [www.TASER.com](http://www.TASER.com) for additional maintenance instructions.

Check expiration of TASER cartridges (5-year expiration date is listed on the base of the cartridge). Do not use an expired TASER cartridge in the field. They should only be used for training.

## Dropped or Wet X26P CEW

**Do not immerse the CEW in water. If your CEW has been submerged in water or exposed to a significant amount of water for an extended time, remove it from service and contact TASER.**

Follow these steps for a CEW exposed to some moisture *but not submerged in water*.

- 1 Point the CEW in a safe direction and away from your body.
- 2 Shift the safety switch to the down (SAFE) position.
- 3 Safely remove the battery pack.
- 4 Safely remove the TASER cartridge.
- 5 Let the CEW dry out.

**Dry the X26P CEW thoroughly (at least 24 hours). Do not use an external heat source such as a microwave oven or hair dryer to dry the X26P CEW.**

- 6 Point the CEW in a safe direction and away from your body and ensure that the safety switch is in the down (SAFE) position.
- 7 Safely reinstall the battery pack.
- 8 Wait 1 minute before proceeding to the next step. Confirm that the CEW is not getting warm.
- 9 Shift the safety to the up (ARMED) position.
  - If the CEW discharges without the trigger being pressed, shift the safety switch to the down (SAFE) position immediately, remove the battery pack, return the CEW to TASER International per the return policies if the CEW is still under warranty.
  - If the CEW does not discharge, go to step 10.
- 10 Look at the CID to ensure the X26P CEW is functioning properly and the CID is not showing any fault icons.
- 11 Confirm that the LASER and flashlight are working properly.
- 12 Press the trigger switch to test the functioning. Conduct three complete 5-second discharges to confirm the proper pulse rate and observe that the cycle stops at 5 seconds. See the instructions under **Function Test** for more information.
- 13 If the trigger switch does not work, or if the CID shows a critical error icon, shift the safety switch to the down (SAFE) position immediately, remove the battery pack, and return the CEW to TASER International per the return policies if the CEW is still under warranty.
- 14 If the CEW does function normally, shift the safety switch to the down (SAFE) position.
- 15 Connect the CEW to EVIDENCE Sync and confirm the internal time is correct. See the **EVIDENCE Sync User Manual** for more information.
- 16 Confirm that the 3 trigger discharges were recorded properly in the download records.
- 17 Return the CEW to service.

## TASER Online Troubleshooting Guide

A troubleshooting guide is available by visiting [www.TASER.com](http://www.TASER.com). If you need product support on accessories or have any other questions, please contact customer service online at [www.TASER.com](http://www.TASER.com) or at:

U.S.: 1.800.978.2737

International: +1.800.978.2737

## Product Returns

To return a TASER product for service, first follow the procedures at [www.TASER.com](http://www.TASER.com).

**Always perform a complete download from the X26P CEW before returning it for warranty or repair work. Any data information will be lost during servicing work performed by TASER.**

**If the TASER CEW has been exposed to bodily fluids or other bio-hazards, please contact the customer service department at 1.800.978.2737 for specific instructions BEFORE returning the X26P CEW.**

## EVIDENCE.com

You can upload the data from your X26P CEW to EVIDENCE.com or EVIDENCE.com Lite services. EVIDENCE.com Lite is free and allows downloading the X26P CEW, viewing the Event and Pulse logs, and updating the CEW software.

The full EVIDENCE.com pay service allows you to manage video records in addition to your CEW records. Visit [www.evidence.com](http://www.evidence.com) for details.

## EVIDENCE Sync Offline Software

The EVIDENCE Sync software can be used in the Offline mode for CEW users who do not have an EVIDENCE.com account. EVIDENCE Sync Offline enables you to download the Event log to your local computer and print it. Visit [www.evidence.com](http://www.evidence.com) or [www.TASER.com](http://www.TASER.com) for details.

## TASER CAM HD Recorder

The TASER CAM HD recorder allows users to capture vital information prior to, during, and after deployment or potential deployment of the X26P CEW. The TASER CAM HD recorder is an audio-video recording device inserted into a rechargeable X26P CEW power supply that replaces the standard battery pack and is compatible with the X26P CEWs. The TASER CAM HD recorder is activated when the safety switch is in the up (ARMED) position. There is a boot-up time delay of approximately 2 seconds after the safety switch is moved to the up (ARMED) position before it starts to record.

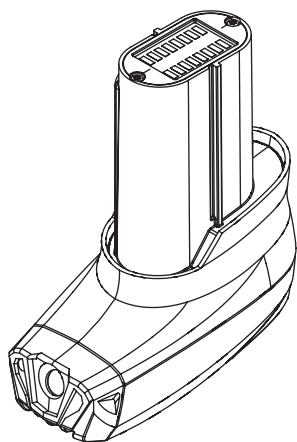

The TASER CAM HD battery is rechargeable and is capable of approximately 100 5-second firings when completely

charged. Charging is accomplished through a 110-volt wall adapter through the USB cable.

The TASER CAM HD can record approximately 1 hour of video at maximum resolution before recording over previous files (continuous loop system).

Video and audio is downloaded via a USB cable and EVIDENCE Sync software to your local computer or to EVIDENCE.com services.

There also is an automatic shutoff (AS) version of the TASER CAM HD recorder that emits an alarm and shuts down the energy cycle after 5 seconds, like the APPM and XAPPM battery packs.

## Holsters

Several holsters are designed for use with the X26P CEW. Both right- and left-handed configurations are available. Visit our website at [www.TASER.com](http://www.TASER.com) for details.



## Additional Information

New TASER brand products are under development. Visit our website at [www.TASER.com](http://www.TASER.com) for the latest information.

See the current product warnings, training materials, licensing agreements, and specification sheets for more information about your TASER product.

Product functions and specifications may change without notice and the actual product may vary from the illustrations in this manual.

## TASER Training Academy

The TASER Training Academy is designed to provide training on the use of TASER-brand CEWs. Training is geared toward the special needs of law enforcement officers, correctional officers, medical personnel, the military, professional security, and private citizens. CEW functions, medical issues, device maintenance, and personal safety are just a few of the topics covered in the offered courses.

Located at TASER's headquarters in Scottsdale, Arizona, the TASER Training Academy features a state-of-the-art classroom facility complete with 48 work stations equipped with power and Internet access, safety mats, and the Ti Training interactive training simulator.

We "fight like we train." It is for this reason that we emphasize hands-on, interactive and scenario-based training. Most of our courses involve some degree of physical activity and participation. We make reasonable efforts to simulate real-life stress and circumstances, to provide realistic training to better prepare the student for success in the field. Through the use of our Ti Training interactive force simulator and Simulation Training Suits, we promote sound use of force judgment, tactics and follow up procedures.

Our cadre of instructors consists of active and former law enforcement officers and military trainers. Many are internationally recognized experts in use of force at all levels with extensive training backgrounds.

All of our instructors are committed to providing high-level training and to forming lasting relationships to support our students long after they leave the TASER Training Academy.

For more information visit our website [www.TASER.com](http://www.TASER.com) or give us a call at 1.800.978.2737.

Courses:

- TASER Conducted Electrical Weapon Instructor Course
- TASER Online User Course

- TASER Master Instructor Course
- TASER Technical Solutions and Investigations Course
- TASER Use of Force, Risk Management and Technical Solutions Seminar

## Medical Research

TASER CEWs are among the most extensively studied force options. Numerous CEW-related medical and field studies have been published. For more information go to [www.TASER.com](http://www.TASER.com).



# TASER

Windows is a trademark of Microsoft Corporation.

M26, TASER CAM, Trilogy, X2, X26, X26P, and XP25 are trademarks of TASER International, Inc. TASER is a trademark of TASER International, Inc., registered in the African Intellectual Property Organization (OAPI), Australia, Canada, the European Union, Hong Kong, India, Israel, Malaysia, New Zealand, Singapore, South Africa, and the USA. X2 is a trademark of TASER International, Inc., registered in Australia, the European Union, Hong Kong, and New Zealand. X3 is a trademark of TASER International, Inc., registered in the USA. Ⓢ is a trademark of TASER International, Inc., registered in Australia, the European Union, India, Malaysia, and the USA. All rights reserved. © 2015 TASER International, Inc.

MMU0042 Rev: B